

B

B

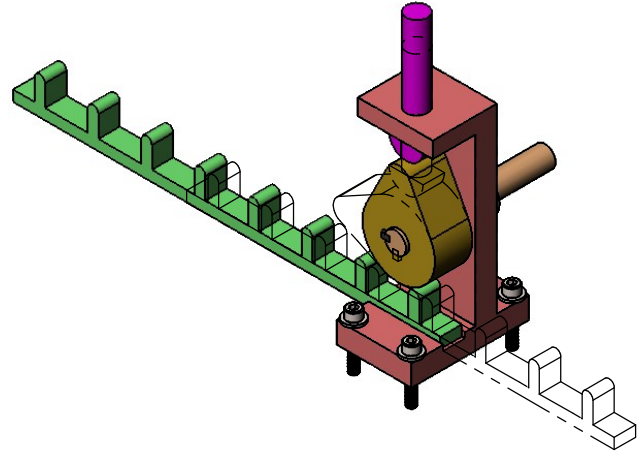
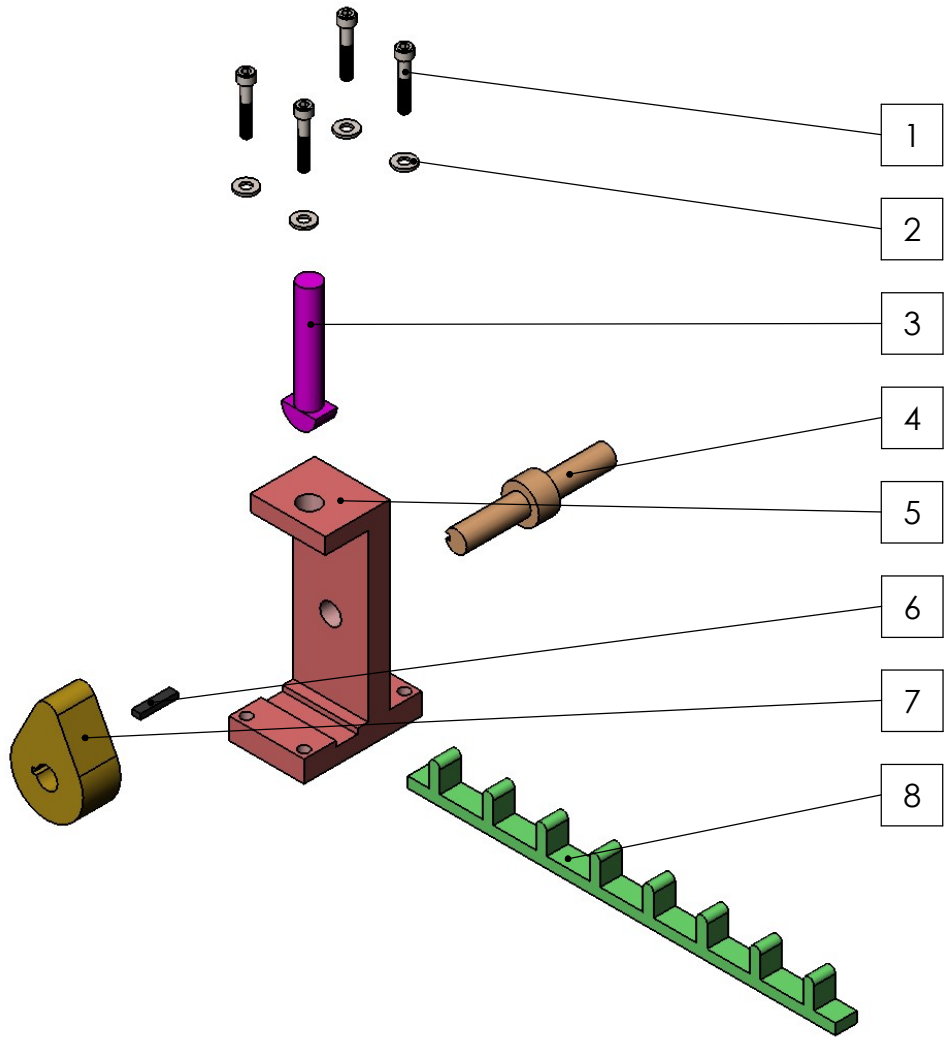

ITEM NO.	PART NUMBER	MATERIAL	QTY.
1	socket head cap screw_am		4
2	flat washer narrow_am		4
3	FOLLOWER		1
4	SHAFT		1
5	BASE		1
6	KEY		1
7	CAM		1
8	RACK		1

A

A

PROPRIETARY AND CONFIDENTIAL		UNLESS OTHERWISE SPECIFIED:		NAME	DATE
THE INFORMATION CONTAINED IN THIS DRAWING IS THE SOLE PROPERTY OF ALEX SPAGNOLO. ANY REPRODUCTION IN PART OR AS A WHOLE WITHOUT A WRITTEN PERMISSION IS PROHIBITED.		DIMENSIONS ARE IN MM		DRAWN	PALLAVI
		TOLERANCES:		CHECKED	MAR 28-17
		FRACTIONAL ±		ENG APPR.	
		ANGULAR: MACH ± BEND ±		MFG APPR.	
		TWO PLACE DECIMAL ±0.08		Q.A.	
		THREE PLACE DECIMAL ±0.04		COMMENTS:	
		INTERPRET GEOMETRIC TOLERANCING PER: ANSI 3RD ANG.			
		MATERIAL VARIOUS			
NEXT ASSY	USED ON	FINISH N/A			
APPLICATION		DO NOT SCALE DRAWING			

LEONARDO COLLEGE 

TITLE:
CAM ASSY

SIZE	DWG. NO.	REV
A	1001	

SCALE: 1:5 SHEET 1 OF 3

2

1

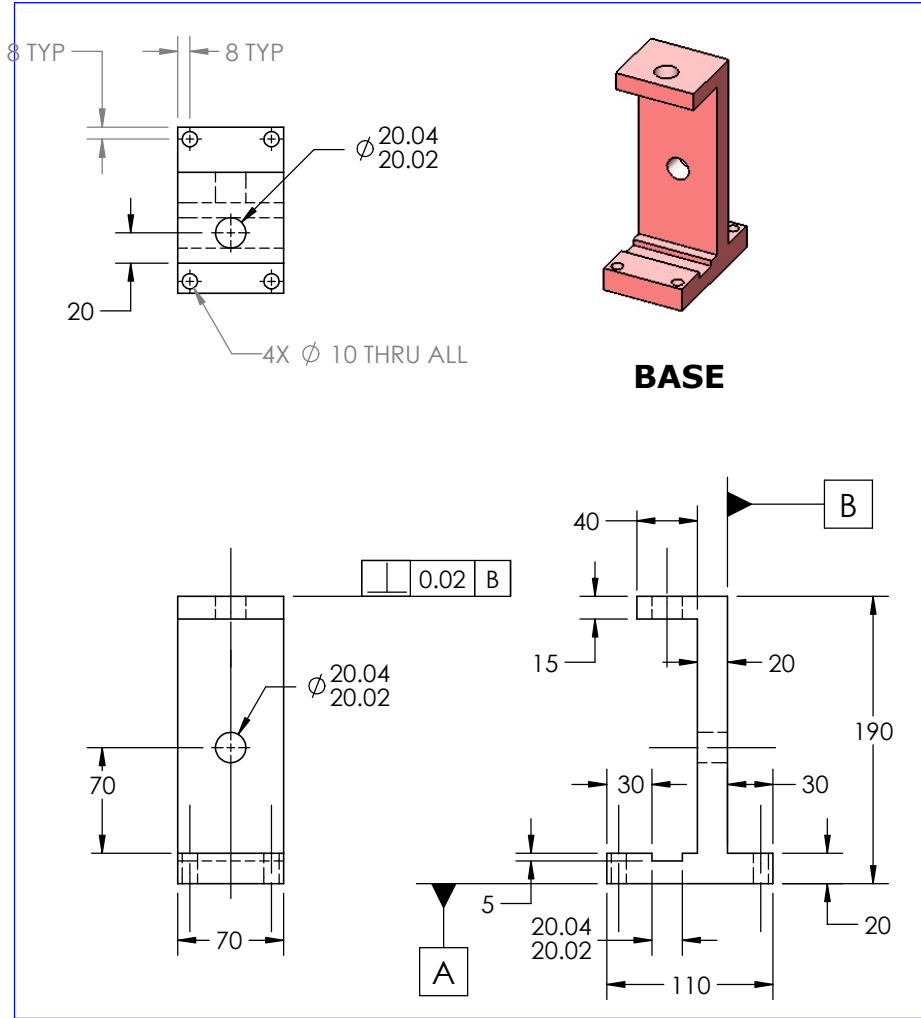

BASE

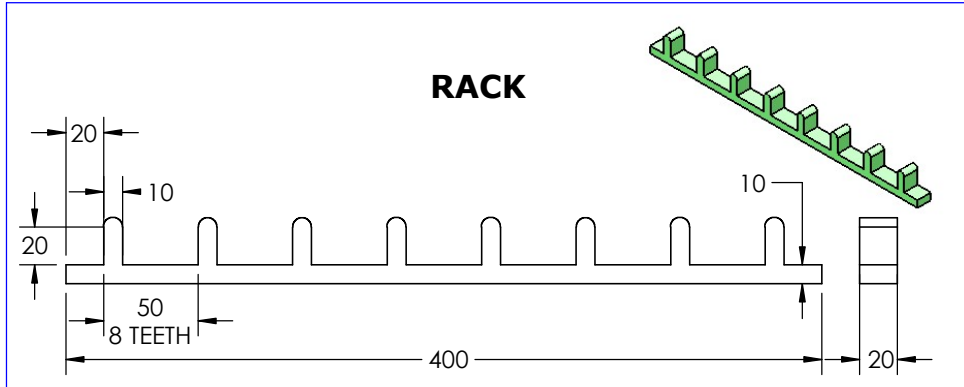

RACK

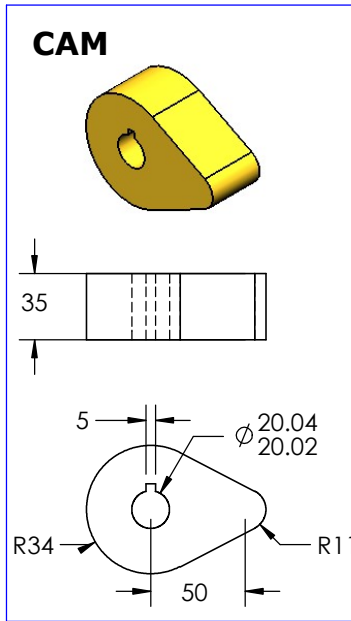

CAM

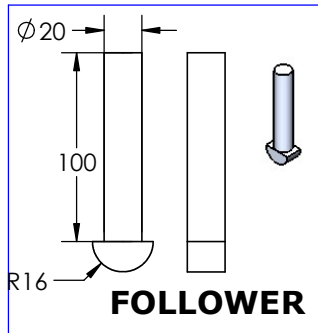

FOLLOWER

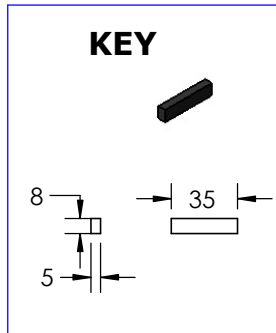

KEY

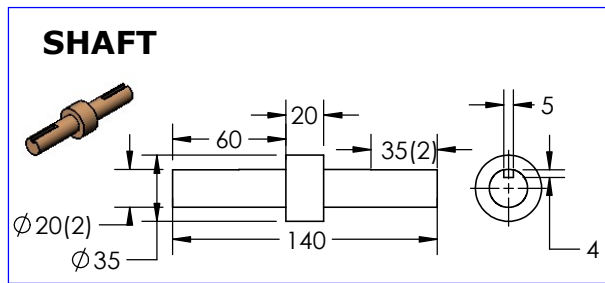

SHAFT

B

B

A

A

PROPRIETARY AND CONFIDENTIAL		UNLESS OTHERWISE SPECIFIED:		NAME	DATE	LEONARDO COLLEGE 	
THE INFORMATION CONTAINED IN THIS DRAWING IS THE SOLE PROPERTY OF ALEX SPAGNOLO. ANY REPRODUCTION IN PART OR AS A WHOLE WITHOUT A WRITTEN PERMISSION IS PROHIBITED.		DIMENSIONS ARE IN MM TOLERANCES: FRACTIONAL ± ANGULAR: MACH ± BEND ± TWO PLACE DECIMAL ±0.08 THREE PLACE DECIMAL ±0.04		DRAWN	PALLAVI		MAR 28-17
NEXT ASSY		MATERIAL		CHECKED			
USED ON		CARBON STEEL		ENG APPR.			
APPLICATION		FINISH		MFG APPR.			
		0.8 MMETERS		Q.A.			
		DO NOT SCALE DRAWING		COMMENTS:		TITLE:	
				TOLERANCES TO BE MET AFTER CADMIUM PLATING.		CAM ASSEMBLY COMPONENTS	
				WASH PART WITH VARSOL BEFORE SHIPPING.		SIZE	
						DWG. NO.	
						A	
						1002	
						REV	
						SCALE: 1:5	
						SHEET 2 OF 3	

2

1

B

B

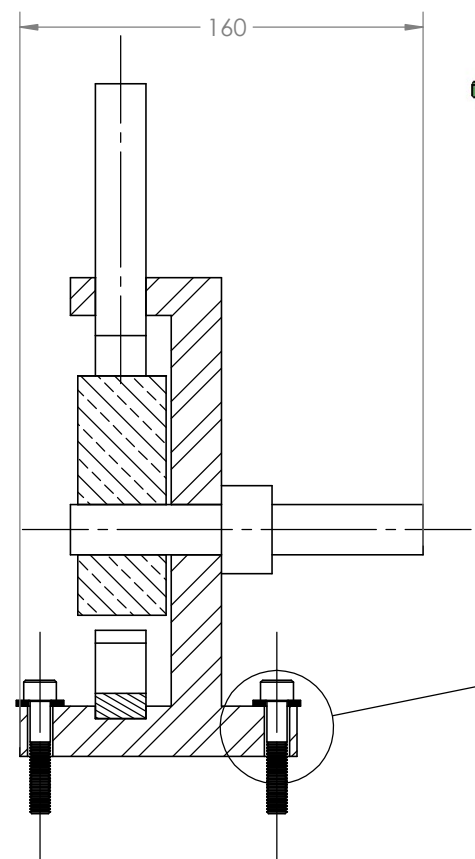
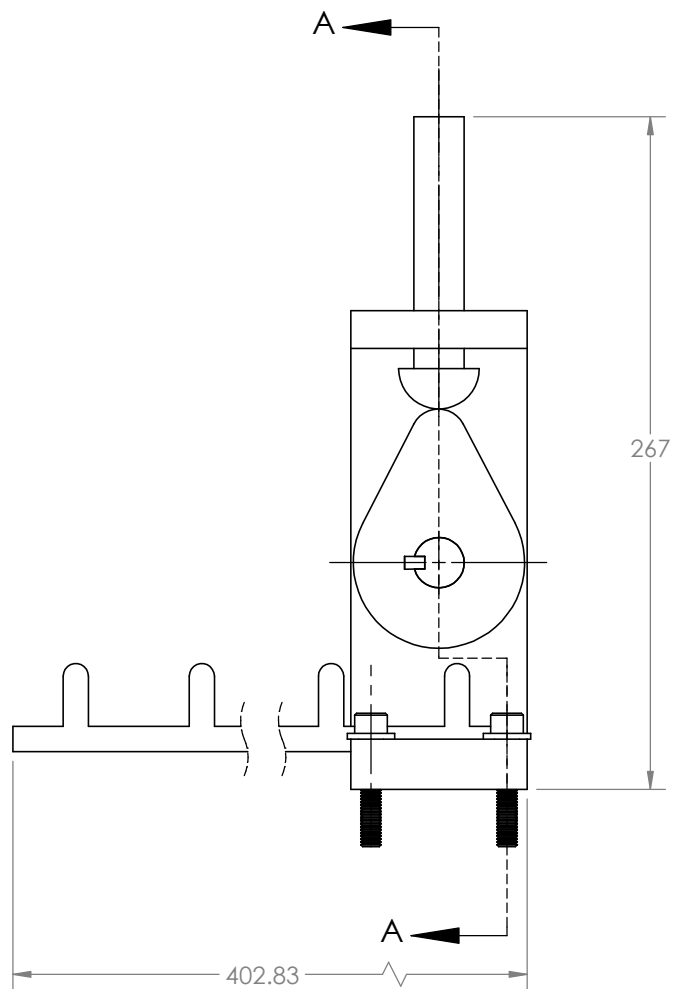

SECTION A-A

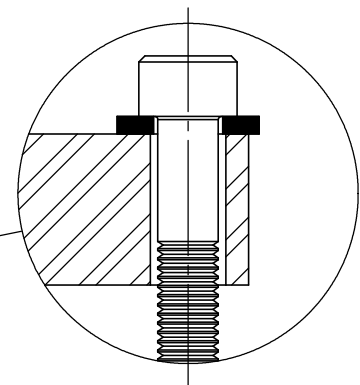
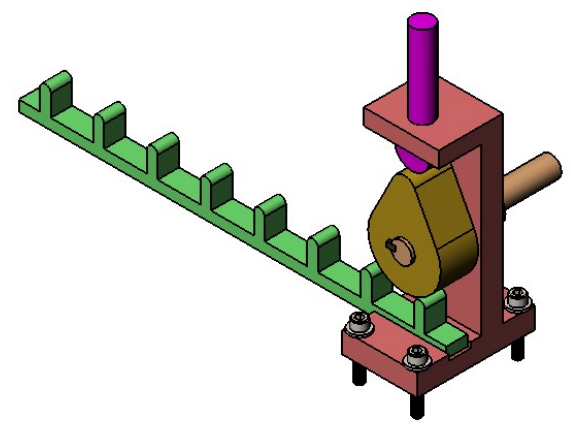

DETAIL D
SCALE 1 : 1

A

A

PROPRIETARY AND CONFIDENTIAL		UNLESS OTHERWISE SPECIFIED:		NAME	DATE	LEONARDO COLLEGE 	
THE INFORMATION CONTAINED IN THIS DRAWING IS THE SOLE PROPERTY OF ALEX SPAGNOLO. ANY REPRODUCTION IN PART OR AS A WHOLE WITHOUT A WRITTEN PERMISSION IS PROHIBITED.		DIMENSIONS ARE IN MM TOLERANCES: FRACTIONAL ± ANGULAR: MACH ± BEND ± TWO PLACE DECIMAL ±0.08 THREE PLACE DECIMAL ±0.04		DRAWN	PALLAVI	MAR 29-17	TITLE:
		INTERPRET GEOMETRIC TOLERANCING PER: ANSI 3RD ANG.		CHECKED			SECTION OF CAM ASSEMBLY
		MATERIAL VARIOUS		ENG APPR.			
NEXT ASSY	USED ON	FINISH N/A		MFG APPR.			SIZE DWG. NO. REV
APPLICATION		DO NOT SCALE DRAWING		Q.A.			A 1003
				COMMENTS:			SCALE: 1:3 SHEET 3 OF 3

2

1